



Product Description

The SLC-RC Switch is used as a replacement for the ring control receiver and can switch up to 3 independent phases.

The switching control can be configured depending on the ambient brightness, time, external inputs, and Astro clock. The configuration and monitoring of the switching function can be done conveniently from the office via the web application: SL-Control or directly on site with the help of the SL-Configurator.

Optionally, a smart meter can be connected. Using the smart meter, current, voltage, power and energy are captured for each phase and visualized graphically in the web application.

BENEFITS

- Replacement for Ring control for on-site and/or remote control of connected street lights by esave SL-Control.
- Monitor street light controllers over the mesh network and gateway functionality.
- Access measurement data through the esave SL-Control web application.
- Integration of Smart Meter for monitoring energy consumption.
- Supports LTE Cat M1, NB-IoT NB2, EGPRS.

FEATURES



Remote Management

The Light Management Platform provides real-time and historical data of the entire lighting network. It allows the remote management and control of all connected lighting points using a user-friendly cloud interface.



On-Site Management

The intuitive, easy-to-use configuration tool allows the on-site configuration of all parameters (i.e., dimming level etc.) for either an individual or a group of luminaires.



Mesh Network

The Communication is ensured via an automatic, organizing 2.4 GHz mesh network. Each streetlight communicates with all luminaires which can be reached.



Automatic GPS Positioning

The GNSS receiver provides precise, geo-located date/time data, enabling the accurate and automatic control of the lighting behavior.



Global Cellular Connectivity

Preinstalled eSIM for instant data connection worldwide. Protocols supported: LTE Cat M1, NB-IoT NB2, EGPRS.



AstroDim

AstroDim provides the accurate sunrise and sunset timing of the very location as a basis for the definition of the light control profiles.



Built-In Relays

The three integrated relay outputs can be directly controlled through the web application and react immediately on measurement data by connected devices.



Smart Meter

Phase by phase, the SLC-RC Switch can capture current, voltage, power and energy and transmit this data to the web application, which displays it graphically.



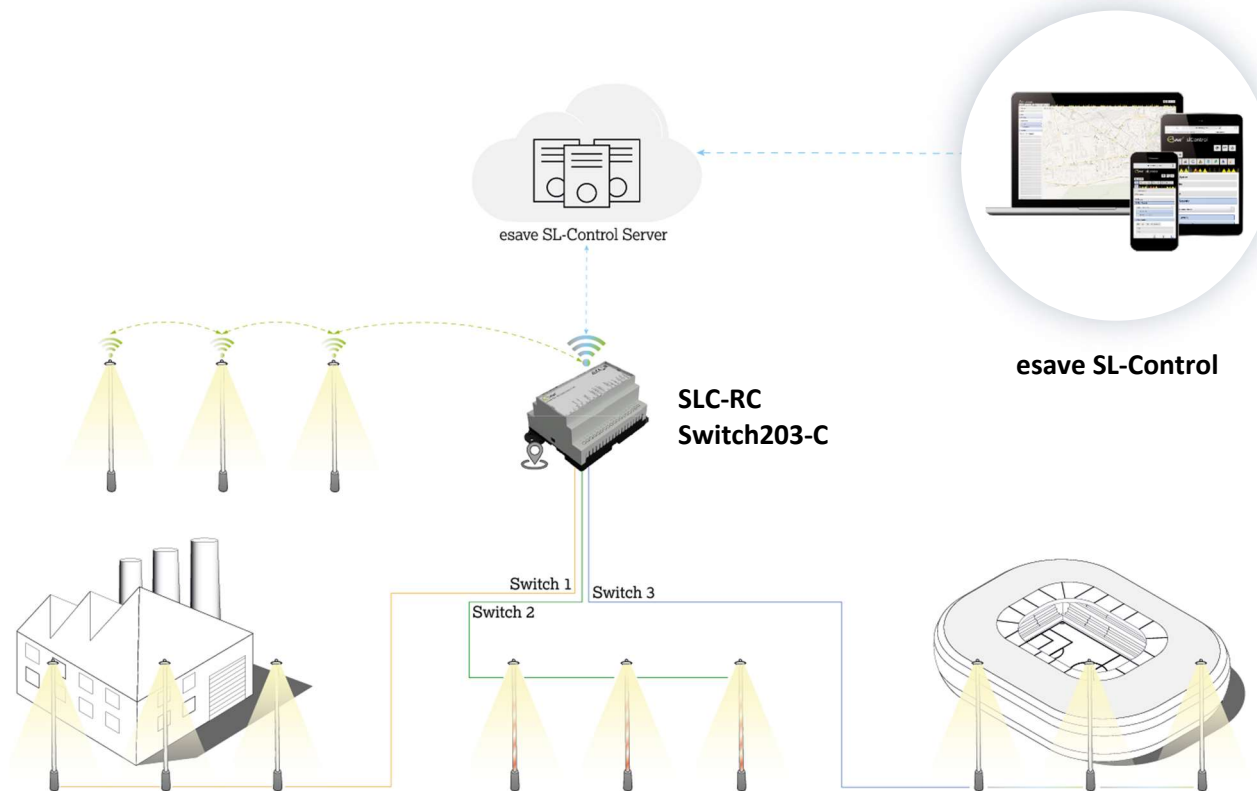

MOUNTING CONTROL CABINET

Fast and simple mounting on to standard DIN EN 60715 TH35 rails enables the SLC-RC Switch203-C to be mounted directly inside a standard control cabinet.



MOUNTING ON WALLS

If a DIN rail is not available, the SLC-RC Switch203-C can be mounted on a wall with the supplied wall bracket. The bracket can be easily attached to the Switch housing without screws.



DIMENSIONS

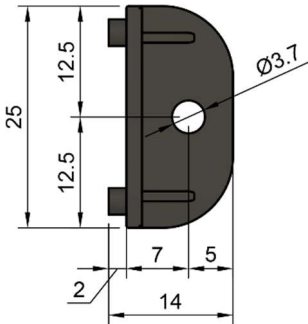
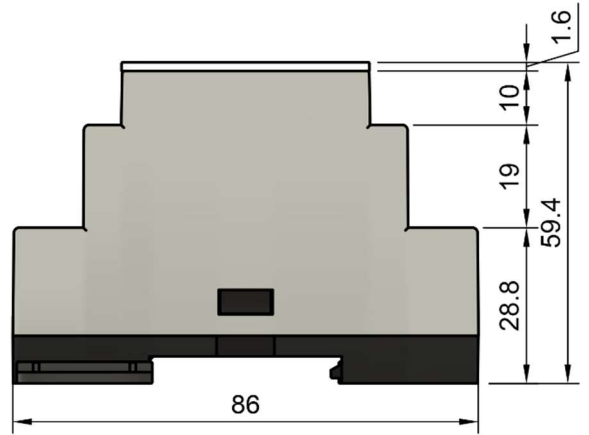
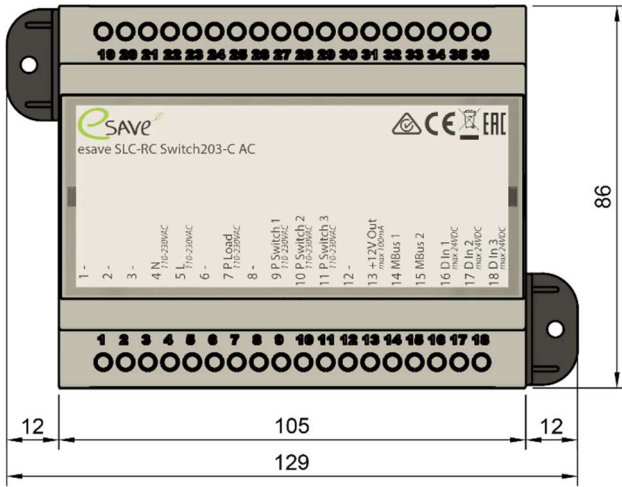

WIRING

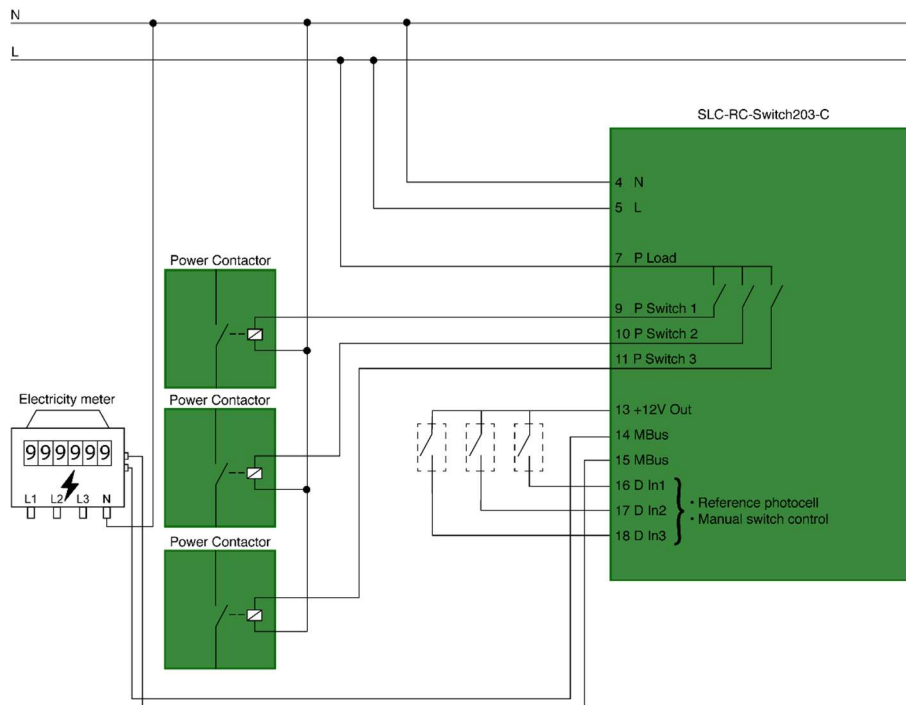

Maximum Ratings

Supply voltage	85 – 305 V AC
Current input	70 mA
Storage temperature	-40...+90 °C

Operating Characteristics

Supply voltage range	110 – 240 V AC typ. 230 V AC
Power usage (230 V AC eMTC)	0.8 W max. 1.3 W
Power usage (230 V AC GSM)	0.8 W max. 2.5 W
Digital signal input	V _{HIGH} Level: 10.5 – 12 V V _{LOW} Level: 0.0 – 4 V
Operating temperature	-30...+80 °C
Protection class	IP20

Relais Output Characteristics

Load voltage	70 – 240 V AC typ. 230 V AC
Frequency	45 – 65 Hz typ. 50 Hz
Load current	0.02 – 2 A*

***Note:** Depending on the ambient temperature

1. Load current vs. ambient temperature characteristics

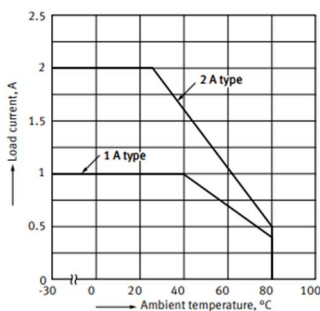

Mesh characteristics

RF frequency range	2.420 – 2.480 GHz
RF nominal output power	+8 dBm
Receiver sensitivity	-100 dBm

Cellular characteristics

Protocols	LTE Cat M1, NB-IoT NB2, EGPRS
Frequency Bands (MHz)	CAT M1: B1/B2/B3/B4/B5/B8/B12/B13/B18/B19/B20/B25/B26/B27/B28/B66/B8 NB-IoT NB2: B1/B2/B3/B4/B5/B8/B12/B13/B18/ B19/B20/B25/B28/B66/B71/B8 EGPRS: 850/900/1800/1900 MH

3-in-1 Puck Antenna (Optional)

Connection problems in the control cabinet? The SLC-RC Switch can now be ordered with three antenna connectors. The 3-in-1 puck antenna will be mounted on the outside of the control cabinet and connected to the SLC-RC Switch.

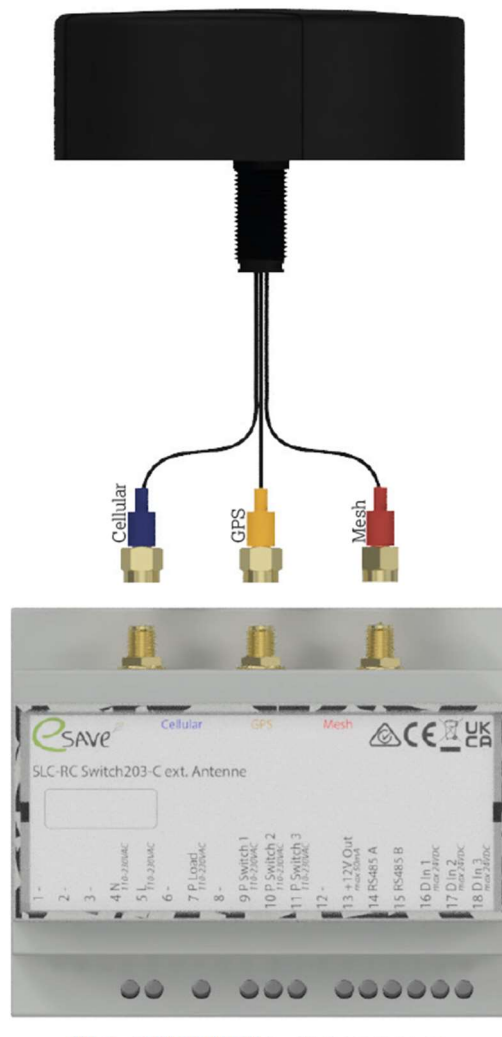

3-in-1 puck antenna

**SLC-RC Switch203-C
with antenna connectors**