

## Product Description

The SLC-Motion203 is a smart street light controller for LED luminaires with Zhaga connector system.

It offers intelligent street light control and a "light on demand" solution in one highly integrated product. The adjustable motion sensor automatically responds when detecting an object in the detection area, and communication is enabled via an automatic 2.4 GHz mesh network.

The SLC-Motion203 is a D4i ready / Type A device and SR certified

## BENEFITS

- Display of the current luminaire status data.
- Evaluation of traffic volume.
- Display of energy consumption.
- Operational cost savings through real-time monitoring and real-time maintenance.

## FEATURES



### Mesh Network

The Communication is ensured via an automatic, organizing 2.4 GHz mesh network. Each streetlight communicates with all luminaires which can be reached.



### Remote Management

The Light Management Platform provides real-time and historical data of the entire lighting network. It allows the remote management and control of all connected lighting points using the cloud.



### On-Site Management

The intuitive, easy-to-use configuration tool allows the on-site configuration of all parameters (i.e., dimming level etc.) for either an individual or a group of luminaires.



### AstroDim

AstroDim provides the accurate sunrise and sunset timing of the very location as a basis for the definition of the light control profiles.



### Brightness Sensor

With the integrated brightness sensor, the light can be automatically switched on or off depending on the ambient light level.



### Tilt Sensor

Detects X, Y, and Z-axis movements through integrated inclination sensing. Generates alerts when changes in inclination occur, such as in the event of a collision of a road user with a pole.



### Temperature Sensor

With the integrated temperature sensor, the controller can be actively monitored. By regularly checking the information about the luminaire status, proactive maintenance and failures can be avoided.



### Motion Sensor

Through the use of motion sensors, the lighting becomes dynamic. Once the sensors register analogue movement in the illumination area, light intensity is automatically increased to a higher level.





The Communication is ensured via an automatic, organizing 2.4 GHz mesh network. Each streetlight communicates with all luminaires which can be reached.

## DIMENSIONS

### SLC-Motion203



<b>Width</b>	81.5 mm
<b>Dome width</b>	75 mm
<b>Height</b>	32.5 mm
<b>Product weight</b>	145 g

### Zhaga Connector

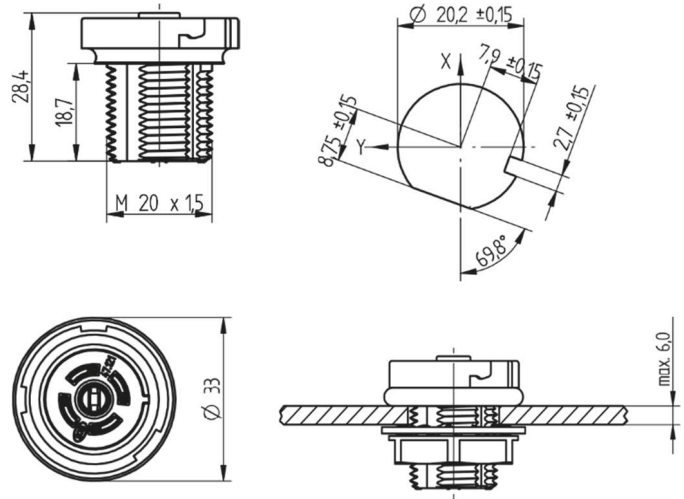

<b>Outer diameter</b>	30.0 mm
<b>Height without plug</b>	28.4 mm
<b>Thread length</b>	18.7 mm
<b>Thread pitch</b>	M20 x 1.5
<b>Material</b>	PBT
<b>Wire size</b>	20-16 AWG (0.5 - 1.5 mm <sup>2</sup> )
<b>Mounting</b>	Torque mounting nut 1.8 to 2.4 Nm using a 27 mm hex socket

## WIRING

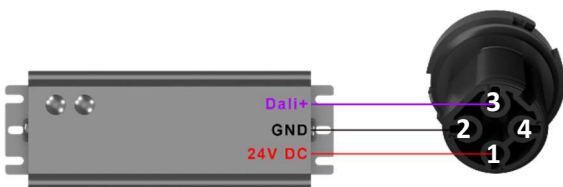

## INSTALLATION

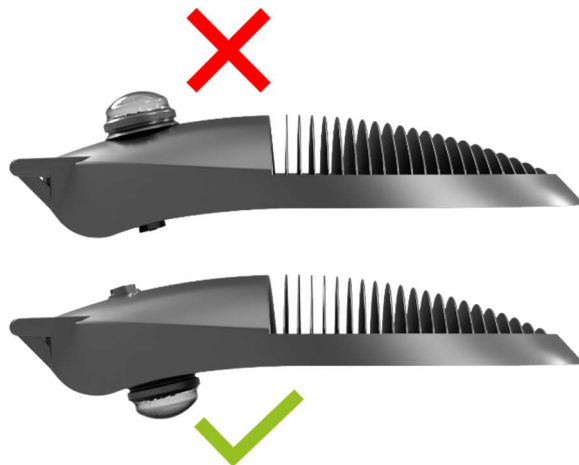

## SENSOR ALIGNMENT

- Rotate the sensor until the small marking (red) aligns with the street direction
- This results in a detection field of 45° for optimal performance
- The raised part should be at back
- The PIR adapter allows the tilt of the sensor in all directions

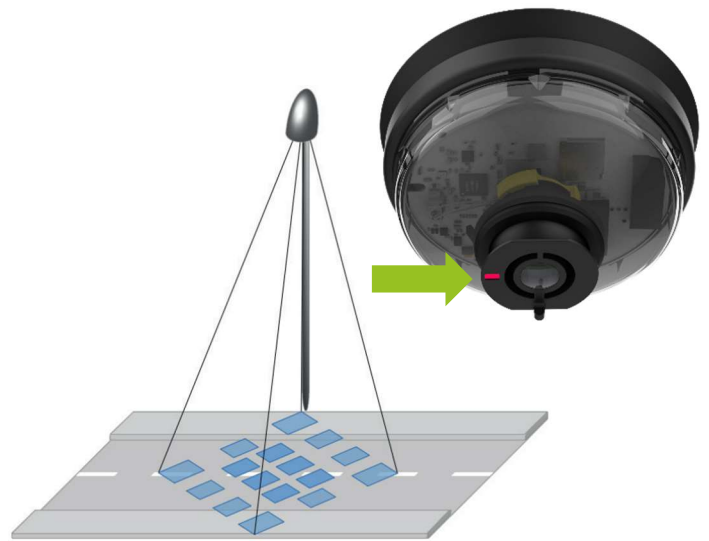

## Alignment Angle

Height	Alignment angle ( $\alpha$ )				
		0°	10°	20°	30°
5m	a	8.4	8.8	10.5	14.6
	b	8.4	8.5	8.9	9.7
6m	a	10.1	10.6	12.6	
	b	10.1	10.2	10.7	
7m	a	11.7	12.4	14.7	
	b	11.7	11.9	12.5	
8m	a	13.4	14.2		
	b	13.4	13.6		
9m	a	15.1	15.9		
	b	15.1	15.3		
10m	a	16.8	17.7		
	b	16.8	17.0		
11m	a	18.5			
	b	18.5			

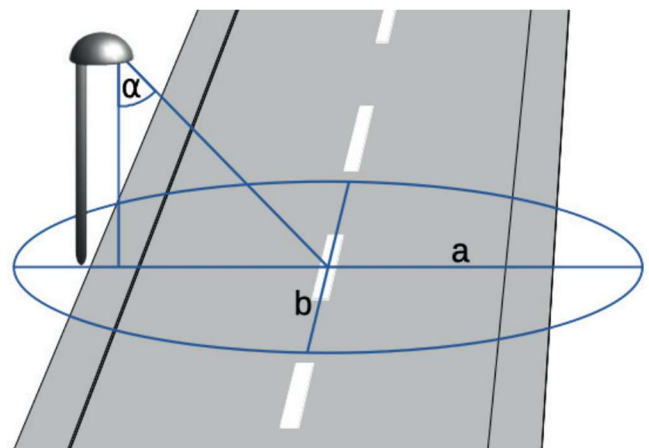

- SLC-Motion203-C ST
- SLC-Motion203-C HS

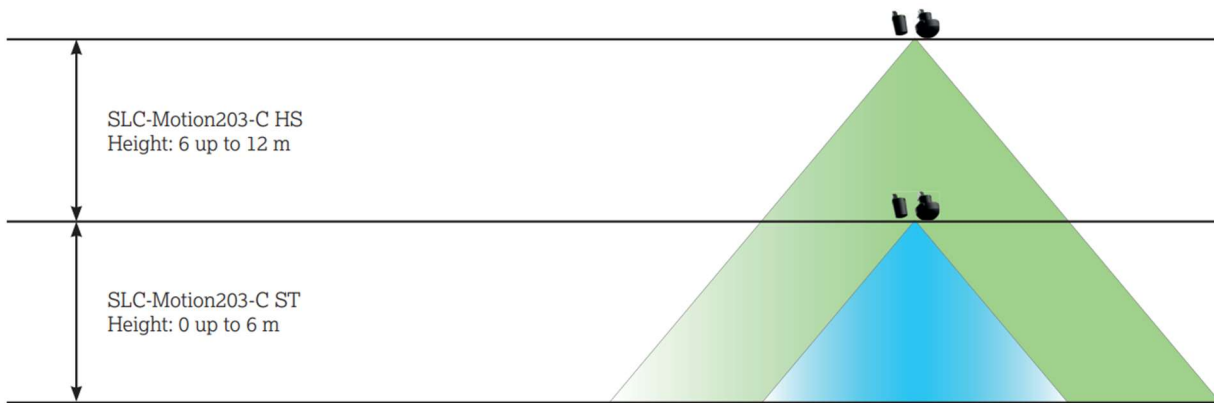

## Operating parameters

Supply voltage range	12 – 30 V DC   typ. 24 V DC
Current input (24 V DC)	7 – 15 mA
Power usage (24 V DC)	180 mW
Operating temperature	-40...+75 °C
DALI bus input current	max: 250 mA
Protection class	IP66

## Communication characteristics

RF frequency range	2.420 – 2.480 GHz
RF nominal output power	+8 dBm
Receiver sensitivity	-100 dBm

## Materials & Colors

Dome material	Polycarbonate
Dome color	Transparent Smoke Gray
Body material	PBT
Body color	Grey

## Approvals and certifications

Category	Declaration / Certificates
CE conformity	CE compliant
Hazardous substances	RoHS compliant
Flammability rating housing	UL Recognized Flame Class Rating: UL 94 V-0
EMC / ERM ratings	EN 300 328
	EN 301 489-1
	EN 301 489-17
	EN 61000-6-2
Safety rating	EN 62368-1



# SLC-Motion203